

STC-642 Series, Data/Signal Line Protection

The STC-642 series of surge suppressors are dual pair (four wire) modules using three-stage hybrid technology. This module addresses over voltage transients with gas tubes and silicon avalanche components. In addition, sneak and fault currents are mitigated with resettable fuses (PTCs). The PTCs increase resistance several orders of magnitude when over currents exceed safe levels. A normal state resumes when over currents are removed. The ability to self restore in this manner significantly increases suppressor performance and survivability.

The STC-642 card edge module is gold-plated, double sided and is designed to mate with the STC-642 gold-plated female terminal connector (sold separately). When snapped together, the data circuits pass thru the protector in a serial fashion from the four Field Side terminals to the four Electronics Side terminals. Terminals 1 or 10 of the STC-PCB1B must be attached to building approved ground.

Features

- Lightning Protection for Low Voltage Data
- Signal Lines
- Three-Stage Protection
- Sneak/Fault Current Protection
- Resettable Solid-State Fuses - PTCs
- Low Capacitance Option for High Speed Data
- Plug-in Module / Requires PCB1B Base
- Fast Response Time
- UL Listed 497B
- 5 Year Limited Warranty

Selection Table

Catalog Number	Description
STC-PCB1B	Base for all STC-642 models. Designed to accommodate up to 10 AWG wire. It offers Flat/Phillips screws and can be mounted using 2 #6 size screws. Must be ordered separately.
STC-FM4-DRC	Optional DIN Rail Mounting Clip for STC-PCB1B



Specifications

Description	STC642-020*	STC642-036*
Peak Surge Current (10 times)	8x20 s .. 10kA 10x700 s 500A per line	
Life Expectancy	8x20 s (2000A) .. >100 occurrences 10x700 s (400A)	
Response Time	<1ns	
Voltage Clamp	20	36
Technology	SAD Hybrid	
Resistance	5 (typical)	
Capacitance (typical)	1500pf	
Operating Temperature	-40°C to +85°C	
Weight	2 oz.	
Dimensions H x W x L (STC-642 & PCB1B)	2.05 x 1.0 x 2.4	
Certifications	UL 497B	
Warranty	5 Years	

*Part number STC-PCB1B sold separately

STC-642 Series, Data/Signal Line Protection

Wiring Diagram (PIN Assignments)

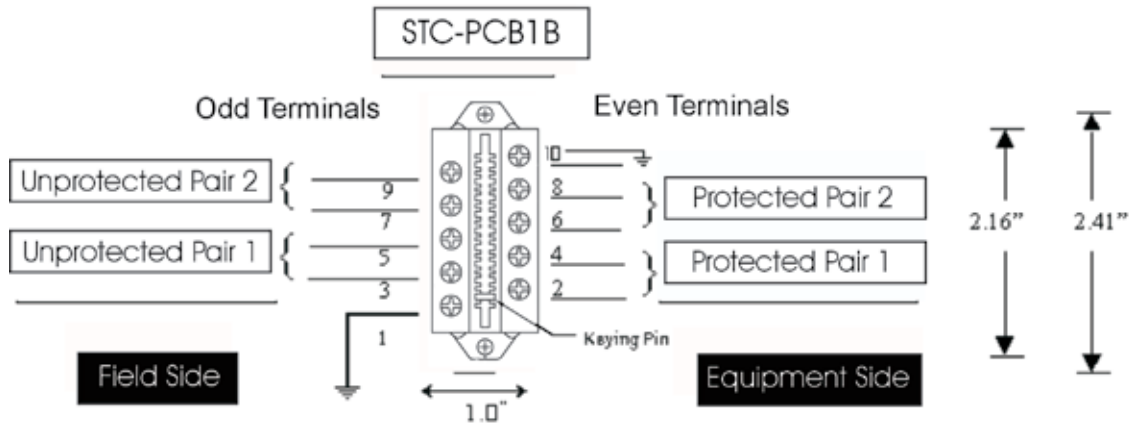

Ground Terminal 1 or 10 (internally tied together) to building approved ground. The STC-PCB1B accommodates 24 to 10 AWG wire.

The hybrid design of this product includes series resistance. Do not place this product in service on any signal line capable of supplying more than 150 milliamperes continuously.

These protectors are intended for indoor use on communication loop circuits which have been isolated from the Public Switch Telephone Network.

The communication loop circuits shall not be exposed to accidental contact with the electric light or power conductors. The protectors shall be installed per the applicable requirements of the National Electric Code, ANSI/NFPA 70.

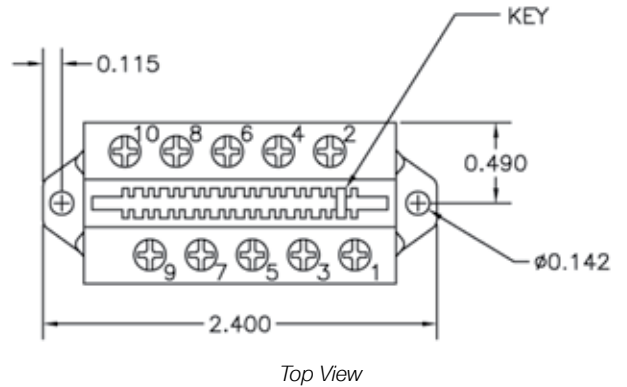

Top View



Side View

Part Numbers by Application

STC642-036 & STC-PCB1B for 4-20 ma Signal

STC642-020 & STC-PCB1B for RS232